



SCIENTIFIC AND TECHNICAL JOURNAL  
Namangan Institute of Engineering and Technology

«DEPENDENCE OF THE TWO-DIMENSIONAL COMBINED  
DENSITY OF STATES ON THE ABSORBING PHOTON ENERGY IN  
GaAs/AlGaAs AT QUANTIZING MAGNETIC FIELD»

Erkaboev Ulugbek

Professor

Sayidov Nozimjon

Doctoral student

Namangan Institute of Engineering and Technology

<https://doi.org/10.5281/zenodo.7951038>



ISSN 2181-8622

**Manufacturing technology problems**



**Scientific and Technical Journal  
Namangan Institute of  
Engineering and Technology**

**Volume 8  
Issue 1  
2023**



UDC 621.3.082.782

## DEPENDENCE OF THE TWO-DIMENSIONAL COMBINED DENSITY OF STATES ON THE ABSORBING PHOTON ENERGY IN GaAs/AlGaAs AT QUANTIZING MAGNETIC FIELD

ERKABOEV ULUGBEK

Professor of Namangan Institute of Engineering and Technology  
E-mail: [erkaboev1983@gmail.com](mailto:erkaboev1983@gmail.com), phone: (+99893) 0523883

SAYIDOV NOZIMJON

Doctoral student of Namangan Institute of Engineering and Technology  
E-mail: [sayidovnozimjon@gmail.com](mailto:sayidovnozimjon@gmail.com), phone: (+99899)8705868

### Abstract:

**Objective.** The influence of the two-dimensional density of states on the oscillations of the transverse electrical conductivity in heterostructures with rectangular quantum wells is studied. A new analytical expression is derived for calculating the temperature dependence of the oscillations of the transverse electrical conductivity and magnetoresistance of a quantum well.

**Methods.** Oscillations of the electrical conductivity and magnetoresistance of a narrow-window quantum well with a nonparabolic dispersion law are studied. The proposed theory was used to study the results of experiments on a narrow-gap quantum well ( $\text{In}_x\text{Ga}_{1-x}\text{Sb}$ ).

**Results.** A new analytical expression is derived for calculating the temperature dependence of the oscillations of the transverse electrical conductivity and magnetoresistance of a quantum well. A mechanism has been developed for the oscillation of the transverse electrical conductivity and magnetoresistance of a quantum well from the first-order derivative of the magnetic field (differential  $\frac{\partial(\rho_{\perp}^{2d}(E, B, T, d))}{\partial B}$ ) at low temperatures and weak magnetic fields.

**Conclusion.** Oscillations of the electrical conductivity and magnetoresistance of a narrow-window quantum well with a nonparabolic dispersion law are studied. The proposed theory was used to study the results of experiments on a narrow-gap quantum well ( $\text{In}_x\text{Ga}_{1-x}\text{Sb}$ ). The Landau levels of the  $\text{In}_x\text{Ga}_{1-x}\text{Sb}$  quantum well in weak magnetic fields, which were not observed in the experiment, oscillate. This has been proven through the  $\frac{\partial(\rho_{\perp}^{2d}(E, B, T, d))}{\partial B}$  theory of magnetoresistance. The experiment shows that the oscillations of the transverse magnetoresistance of the  $\text{In}_x\text{Ga}_{1-x}\text{Sb}$  quantum filament, measured at a temperature of 2 K, transform into a continuous energy spectrum due to thermal washing under the influence of the temperature growth dynamics.

**Keywords:** semiconductor, magneto-optical absorption coefficient; Landau levels; oscillations of the combined density of states; modeling; pressures; temperatures.

**Introduction.** As is known, the influence of external factors (temperature, magnetic field and pressure) on quantum-dimensional heterostructures leads to a change in the position of the energy levels of charge carriers and, consequently, to a shift of the magneto-optical absorption edge[1-20]. The magneto-optical absorption spectrum of nanoscale semiconductors is determined by the energy distance between different minima of the sparse zone. Hence, the width of the

forbidden zone of the quantum well can either decrease or increase due to external influences. Thus, the study of the magneto-optical absorption spectrum near the boundary of its absorption edge provides information about the structure of the energy spectrum of charge carriers near the lower edge of the conduction band and near the upper edge of the valence band of the quantum well, which is essential for determining the magnetic, optical and

electrical properties of nanoscale semiconductors.

The combined densities of quantum well states play an important role in the oscillation of interband magneto-optical absorption. Therefore, in many cases, the matrix element ( $p_{cv}$ ) changes little within the Brillouin zone.

Consequently, the structure of the spectrum mainly determines the combined density of states in quantum-dimensional heterostructures. In works [1-3], a method was developed for calculating the oscillation of the combined density of states in a quantizing magnetic field with a non-quadratic law of dispersion under the influence of temperature and hydrostatic pressure. This method is used in the study of magnetic absorption in narrow-band semiconductors with a nonparabolic dispersion law. A fan diagram of the magnetic absorption spectrum in narrow-band semiconductors is constructed. However, these papers do not consider the temperature dependence of the two-dimensional combined density of states in the allowed zone of a quantum well with a parabolic law of dispersion. That is, the resulting method is applicable only for bulk semiconductor materials.

In addition, in works [4,5], the spectrum of InGaN/AlGaIn/GaN heterostructures with quantum wells is emitted by an LED and analyzed on the basis of a two-dimensional combined density of states model. The considered model of approximation of the luminescence spectra of LEDs in these works was developed for complex heterostructures with multiple quantum wells. In work [6], a random walk in a two-dimensional space consisting of an energy

parameter of the order and an energy correlation function was performed, and a two-dimensional combined density of quantum well states was obtained. The order parameter, susceptibility and correlation function are calculated from the two-dimensional combined density of quantum well states. Numerical calculations of the author show that for the purposes of determining the two-dimensional combined density of states in continuous models, the Wang–Landau transition matrix method can be considered as an alternative to the pure Wang-Landau method. In work [7], an exact mathematical expression is proposed that directly combines the density functions of the states of the resolved zone of a quantum well to create a two-dimensional combined density of states for direct transitions. Using both expressions, the absorption coefficient of the quantum well and the superlattice was calculated, which led to a positive coincidence with the experimental data. In the above literature, the temperature dependence of the oscillation of the two-dimensional combined density of quantum well states in a quantizing magnetic field is not discussed. Also, the work determines the oscillations of the combined density of quantum well states at constant temperatures in the absence of a magnetic field.

**Methods.** The purpose of this work is to determine the effect of a strong magnetic field on the combined density of states in heterostructures with quantum wells.

In the absence of a magnetic field, the dependence of the density of the energy states of the conduction band and the valence band in the quantum well on the energy spectrum of charge carriers are step functions (Fig.1a) [21]:

$$\begin{aligned}
 g_c(E) &= \frac{m_n^e}{\hbar^2 \pi} \sum_n \theta(E - E_n) \\
 g_v(E) &= \frac{m_n^h}{\hbar^2 \pi} \sum_m \theta(E - E_m)
 \end{aligned}
 \tag{1}$$

Here,  $m_n^e$  and  $m_n^h$  are the effective masses of electrons and holes in the dimensional quantization subband in a quantum well numbered  $n$  and  $m$ .  $\theta(E)$  - Heaviside step function.

For direct interband transitions, the combined densities of states are a convolution in energy, which also has a step function in energy [21]:

$$N_{jds}^{2d}(E) = \frac{m_{mn}^*}{\hbar^2 \pi} \sum_{m,n} \theta(E - E_{mn}) \quad (2)$$

Here,  $m_{mn}^*$  is the reduced effective mass of charge carriers for the subzones of dimensional quantization  $n$  and  $m$ , which is calculated by the ratio:  $(m_{mn}^*)^{-1} = (m_n^e)^{-1} + (m_m^h)^{-1}$ .

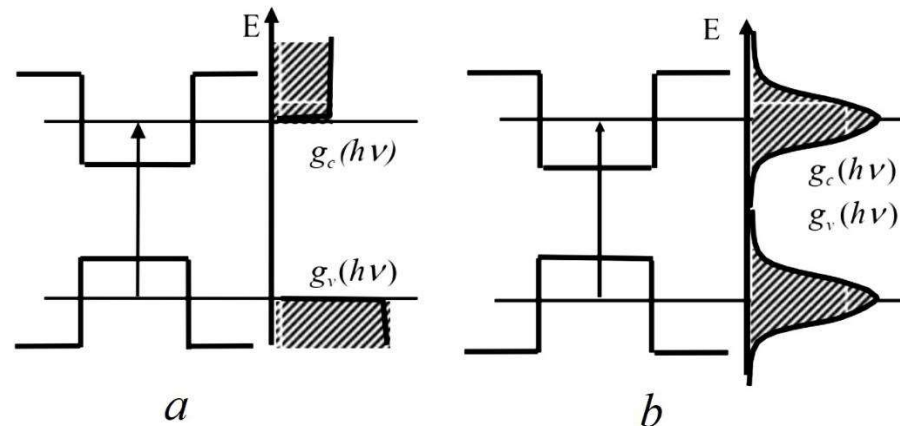

**Fig.1. The energy distribution of the density of electronic states in quantum-dimensional GeSi/Si structures [21]: a - quantum well, b - quantum dot**

If the electronic and hole states in GeSi structures turn out to be size-quantized in all three quasi-momentum components, that is, they represent a quantum dot for charge carriers, then in this case the combined density of states in the allowed band of such a structure is a Gaussian function (Fig. 1b). Then, in the allowed zone there is a zero-dimensional combined density of states, which is a discrete non-decreasing function. In this case, the combined density of states is described using the so-called Dirac delta function  $\delta(E)$ :

$$N_{jds}^{0d}(E) = \sum_{l,m,n} \delta(E - E_{lmn}) \quad (3)$$

The combined density of states is a collection of infinitely narrow and high peaks (Fig.1b). All the results obtained above are valid for cases without the influence of quantization of the magnetic field, temperature and pressure. Specific questions arise: how to determine the combined density of states in quantum-dimensional direct transitions of

heterostructures in the presence of a strong magnetic field? How does the dynamics of temperature rise affect this process?

Let's calculate the dependence of the combined density of states on the quantizing magnetic field in two-dimensional semiconductor materials with direct allowed transitions. In a quantizing magnetic field, the combined density of states is defined as an integral over all states in the conduction band with energies  $E_C$  and in the valence band with energies  $E_V$  of the quantum well, which satisfy the law of conservation of energy during the magneto-optical transition. Let us analyze the simplest model of a band structure near the edge of the band gap of a straight-band heterostructure with a quantum well under the influence of a strong magnetic field. That is, the valence band of the quantum well is completely filled with charge carriers, and the conduction band is empty. Here, the filling functions of the corresponding states are equal to  $f_V=1$ ,  $f_C=0$ . In addition, in this model, the

dependence of impurity levels on the combined density of quantum well states with the parabolic law of dispersion can be neglected. The magnetic field inductions are directed across (along the Z axis) and will be perpendicular to the XY plane. This

is called a transverse quantum magnetic field.

Hence, in the presence of a strong magnetic field, the laws of dispersion energy are used to calculate the combined density of quantum well states, which can be written as follows:

$$\begin{aligned}
 E_c^{2d}(B, d, n_{cZ}) &= \left(N_L^c + \frac{1}{2}\right) \hbar \omega_c^c + \frac{\hbar^2 \pi^2}{2m_c d^2} n_{cZ}^2 + m_s^c g_c \mu_B H \\
 E_v^{2d}(B, d, n_{vZ}) &= -\left(N_L^v + \frac{1}{2}\right) \hbar \omega_c^v - \frac{\hbar^2 \pi^2}{2m_v d^2} n_{vZ}^2 - m_s^v g_v \mu_B H - E_g^{2d}(0)
 \end{aligned} \quad (4)$$

Here,  $N_L^c, N_L^v$  is the number of Landau levels of charge carriers in the allowed zone of the quantum well;  $\omega_c^c, \omega_c^v$  is the cyclotron frequency of the magnetic field in the conduction band and valence band of the quantum well;  $d$  is the thickness of the quantum well;  $n_{cZ}^2, n_{vZ}^2$  is the number of the dimensional quantization subzone in the conduction band and in the valence band of the quantum well;  $n_{cZ}, n_{vZ}$  is the ordinal number of the quantization levels of electrons and holes along the Z axis, respectively.

Imagine that the electron and valence bands are symmetric, then the condition  $n_{cZ} = n_{vZ} = n_Z$  is fulfilled.  $m_s^c g_c \mu_B H, m_s^v g_v \mu_B H$  is the spin energy in the allowed zone;  $E_g^{2d}(0)$  is the width of the forbidden zone of the quantum well at absolute zero temperature;  $B$  is the induction of the magnetic field.

For  $E_c^{2d}(B, d, n_Z)$  and  $E_v^{2d}(B, d, n_Z)$ , without taking into account spin, magneto-optical transitions will correspond to the law of conservation of energy

$$\begin{aligned}
 E_{cv}^{2d}(B, d, n_Z) &= E_c^{2d}(B, d, n_Z) - E_v^{2d}(B, d, n_Z) \\
 E_{cv}^{2d}(B, d, n_Z) &= E_g^{2d}(0) + \left(N_L^c + \frac{1}{2}\right) \hbar \omega_c^c + \left(N_L^v + \frac{1}{2}\right) \hbar \omega_c^v + \frac{\hbar^2 \pi^2}{2m_{cv}^* d^2} n_Z^2 \\
 h\nu &\geq E_{cv}^{2d}(B, d, n_Z)
 \end{aligned} \quad (5)$$

Where,  $h\nu$  is the absorbed photon energy,  $\nu$  is the frequency of light,  $\frac{1}{m_{cv}^*} = \frac{1}{m_c^*} + \frac{1}{m_v^*}$  is the combined (reduced) effective mass.

In the Z direction, a strong magnetic field does not change the relationship between the energy and the wave vector for the movement of charge carriers. However, for the movement of charge carriers in the direction of perpendicular magnetic induction (in the XY plane), the former quasi-continuous series of energy levels is replaced by a system of discrete Landau levels. Since the effective mass of

electrons and holes is assumed to be constant, the distance between the Landau levels does not depend on the quantum number, which is  $\hbar \omega_c$ . Hence, in the conduction band and the valence band of the quantum well, the movement of free electrons and holes in all three directions is limited. When exposed to a quantizing magnetic field, a quantum well becomes an analogue of a quantum dot. And also, the energy spectrum of charge carriers will be entirely discrete. According to equation (3), when replacing  $E$  with  $h\nu$  and  $E_{lmn}$  with  $E_{cv}^{2d}(B, d, n_Z)$  in the argument  $\delta(E - E_{lmn})$ , we have:

$$N_{jds}^{2d}(h\nu, E_{cv}^{2d}(B, d, N_L^{cv}, n_z)) = \frac{eB}{\pi\hbar} \sum_{N_L^c, N_L^v, n_z} \delta(h\nu - E_{cv}^{2d}(B, d, N_L^{cv}, n_z)) \quad (6)$$

Thus, under the influence of a quantizing magnetic field, the equation (6) can be used to determine the combined density of quantum well states. However, such equations do not take into account the influence of temperature and pressure on the discrete Landau levels of electrons and holes for straight-band quantum wells.

The magneto-optical assimilation range could be a key prerequisite for many volumetric and low-dimensional optoelectronic devices. The method of magneto-optical retention in straight-band heterostructures with quantum wells and  $\alpha_B^{2d}(h\nu, B, d)$  can be communicated as a function of the combined thickness of states. When uncovered to a quantizing attractive field, the combined thickness of states gives a degree of the number of permitted magneto-optical moves between the electronic states of the filled valence band and the vacant electronic states of the conduction band isolated by the photon vitality  $\hbar\nu$ . In well-known logical writing, a few endeavors have been detailed to relate the densities of the vitality states of the allowed zone with the combined thickness of states within the nonattendance and nearness of a attractive field. [4-7]. Be that as it may, all the experimental and rearranged expressions of the combined thickness of states gotten were restricted by the nonappearance of weight and at moo temperatures.

From equation (6) it is clear that for  $h\nu > E_{cv}^{2d}(B, d, N_L^{cv}, n_z)$ , the form of the combined density of states as a function of energies reflects the nature of deltoidness. When exposed to a quantizing magnetic field, the two-dimensional combined density of states  $N_{jds}^{2d}(h\nu, E_{cv}^{2d}(B, d, N_L^{cv}, n_z))$  it is determined

by the energy spectrum of charge carriers in the allowed zone of the quantum well. Experiments show that the density of states of electrons and holes depends on temperature. The temperature dependence of the density of states of electrons and holes in a quantum well is explained by the thermal blurring of discrete Landau levels [22-25]. As shown in works [23,24], the density of electron states in the conduction band of a quantum well at sufficiently high temperatures transforms from discrete Landau levels into a continuous energy spectrum. And at low temperatures, the quantizing magnetic field strongly affects the densities of states in the resolved zone of the quantum well, whereas the continuous energy spectrum decomposes into discrete Landau levels. In this case, as the temperature increases, collisions of charge carriers and thermal motions lubricate the discrete Landau levels, turning it into a continuous spectrum of the density of quantum well states. Hence, the temperature dependence of discrete Landau levels of charge carriers can be described by decomposing the combined density of quantum well states into a series of delta-shaped functions. The temperature dependence of the oscillation of the interband magneto-optical absorption in heterostructures with quantum wells was explained by a study using the delta-shaped functions of two-dimensional combined densities of states. The temperature dependence of the two-dimensional combined density of states is determined by thermal broadening of discrete Landau levels of charge carriers in the allowed zone of the quantum well.

At  $T=0$ , the Gaussian distribution function is delta-shaped and is defined by the following expression [26]:

$$Gauss(E, T) = \frac{1}{kT} \cdot \exp\left(-\frac{(E - E_r)^2}{(kT)^2}\right) \quad (7)$$

In addition, to describe the interband magneto-optical absorption, it is usually assumed that each energy spectrum of a quantum well is blurred according to the Gaussian law with a blurring parameter. This approach can be described by the temperature dependence of the two-dimensional combined density of states in a quantum well. Hence, the deep filled discrete Landau levels of charge carriers in a quantum well depend exponentially on the two-dimensional combined density of states. To calculate the temperature dependence of the two-dimensional combined density of states  $N_{jds}^{2d}(h\nu, E_{cv}^{2d}(B, d, n_z))$  we assume that  $N_{jds}^{2d}(h\nu, E_{cv}^{2d}(B, d, N_L^{cv}, n_z))$  for  $T=0$  equal to the known energy functions  $E_{cv}^{2d}(B, d, N_L^{cv}, n_z)$ . For a heterostructure with quantum wells, in a strong magnetic field, the two-dimensional combined density of states is calculated by the equation (6). With increasing temperature, each combined density of states in the allowed zone of the quantum well with the energy of the conduction band and the valence band  $E_{cv}^{2d}(B, d, N_L^{cv}, n_z)$  is eroded. Thermal blur  $N_{jds}^{2d}(h\nu, E_{cv}^{2d}(B, d, N_L^{cv}, n_z))$  with energy  $E_{cv}^{2d}(B, d, N_L^{cv}, n_z)$  is calculated

by the Shockley-Reed-Hall statistics [27]. Thus, under the influence of a quantizing magnetic field, in the permitted zone of the quantum well, the resulting two-dimensional combined density of states, taking into account the contribution of thermal blurring of all states, will be determined by the sum of all blurring. Hence, at a finite temperature  $T$ , this reduces to the decomposition into a series  $N_{jds}^{2d}(h\nu, E_{cv}^{2d}(B, d, N_L^{cv}, n_z))$  by Gaussian functions, for nanoscale semiconductor structures.

The equation (6) does not take into account thermal blurring of the two-dimensional combined density of states. If we decompose  $N_{jds}^{2d}(h\nu, E_{cv}^{2d}(B, d, N_L^{cv}, n_z))$  in a row according to equations (7), then it is possible to take into account the temperature dependence of the two-dimensional combined density of states in the allowed zone of the quantum well. In a strong magnetic field, temperature blurring of the combined density of quantum well states leads to smoothing of discrete Landau levels of charge carriers, and thermal blurring is calculated using the equation (7). At  $T=0$ , the equation (7) turns into a delta-like function of the form:

$$\text{Gauss}(E, E_i, T) \xrightarrow{T \rightarrow 0} \delta(E - E_i) \tag{8}$$

Thus, it follows from equations (5), (6) and (7) that under the influence of a quantizing magnetic field, the temperature dependence of the combined density of quantum well states is reduced to the following analytical expression:

$$N_{jds}^{2d}(h\nu, E_{cv}^{2d}(B, T, d, N_L^{cv}, n_z)) = \frac{eB}{\pi\hbar} \cdot \frac{1}{kT} \cdot \sum_{N_L^c, N_L^v, n_z} \exp \left[ - \frac{\left( h\nu - \left( E_g^{2d}(0) + \left( N_L^c + \frac{1}{2} \right) \hbar\omega_c^c + \left( N_L^v + \frac{1}{2} \right) \hbar\omega_v^v + \frac{\hbar^2 \pi^2}{2m_{cv}^* d^2} n_z^2 \right) \right)^2}{(kT)^2} \right] \tag{9}$$

Where,  $N_{jds}^{2d}(h\nu, E_{cv}^{2d}(B, T, d, N_L^{cv}, n_z))$  - temperature dependence of the oscillation of the combined density of states in the allowed zone of the quantum well in the presence of a strong magnetic field.  $B$  is

the induction of a transverse quantizing magnetic field.

This new analytical equation expresses the effect of the quantizing magnetic field on the temperature dependence of the two-dimensional combined density of states in



heterostructures with quantum wells. The obtained expression is convenient for processing experimental data on the oscillation of interband magneto-optical absorption in quantum wells at various magnetic fields and temperatures. Thus, a mathematical model describing the effects of external factors (temperature and magnetic field) on the two-dimensional combined density of states in nanoscale semiconductor structures has been obtained.

**Results.** Now, for specific straight-band heterostructures based on quantum wells, we consider the temperature dependence of the two-dimensional combined density of states in a quantizing magnetic field. In work [28], a high-quality heterostructure with a GaAs/AlGaAs quantum well with a width of 14 nm with a small concentration of aluminum (3%) in the barrier layers was investigated. Heterostructures with a GaAs/AlGaAs quantum well were studied at a temperature of 4 K. In the absence of a magnetic field, the band gap of the GaAs quantum well is equal to 1.464 eV (Fig.2). Fig.2 shows the dependence of the two-dimensional combined density of states on the absorbing photon energy for a GaAs quantum well  $d=14$  nm ( $n_z=1$ ) at a temperature  $T=4$  K and a quantizing magnetic field  $B=9$  T. This graph was created by numerical calculation based on equation (9). In Fig.2, the number of discrete Landau levels of charge carriers is fourteen. These peaks (discrete Landau levels of charge carriers ( $N_L^{cv}=14$ )) are observed in the allowed band of the GaAs

quantum well. It shows the two-dimensional combined density of states in a quantizing magnetic field  $\hbar\omega_c = 0,02$  eV at  $T=4$ K,  $kT=4\cdot 10^{-4}$ ,  $\frac{\hbar\omega_c}{kT} = 50$ ,  $kT \ll \hbar\omega_c$ . In this case, the thermal smearing of the Landau levels of charge carriers is very weak and the two-dimensional combined density of states does not feel any deviation from the ideal shape. In this plot, the valence band and conduction band are chosen as symmetrical energy spectra. Then, from the first discrete Landau level of holes ( $N_{L(v)}=0$ ) to  $N_{L(v)}=6$ , they are located higher from the beginning of the ceiling of the valence band of the quantum well. As well as other discrete Landau levels of electrons are located above the bottom of the conduction band of the quantum well.

Fig.3 appears the impact of temperature on the reliance of the two-dimensional combined thickness of states on the retaining photon vitality in direct-gap heterostructures with GaAs/AlGaAs quantum wells ( $d=14$  nm) beneath the activity of a quantizing attractive field. Here, the sum of acceptance of the quantizing attractive field is 9 T and plots of  $N_{jds}^{2d}(\hbar\nu, E_{cv}^{2d}(B, T, d, N_L^{cv}, n_z))$  are made for temperatures of 4 K, 20 K, 40 K, 60K, 77 K. It can be seen from Fig.3 that with expanding temperature, the sharp crests of the Landau levels start to smooth out, and at adequately tall temperatures the discrete vitality densities of states turn into nonstop vitality spectra. These comes about were gotten for a steady quantum well thickness and attractive field.

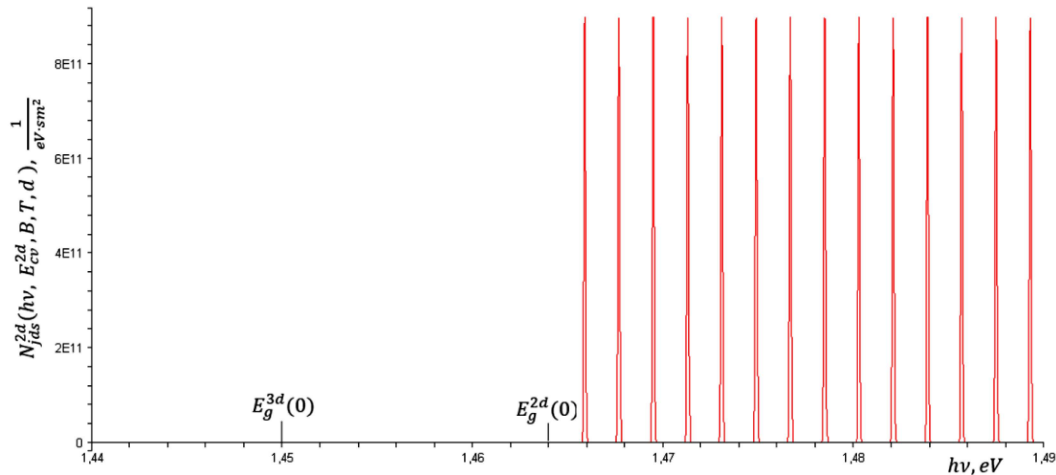
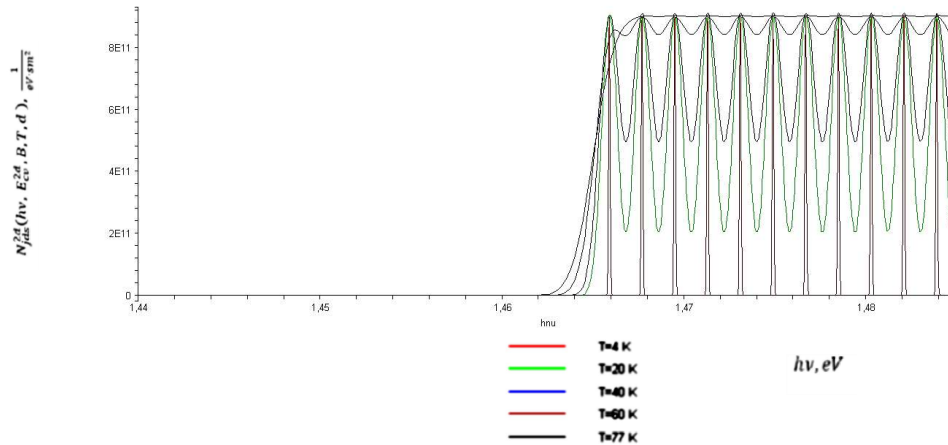

**Fig.2. Dependence of the two-dimensional combined density of states on the absorbing photon energy in direct-gap heterostructures with GaAs/AlGaAs quantum wells (d=14 nm) at a temperature T=4 K and a quantizing magnetic field B=9 T**

With expanding temperature, the sharp crests of the Landau levels of charge carriers start to smooth out (Fig.3) and at  $kT \approx \hbar\omega_c^{cv}$  steadily vanish. Additionally, at adequately tall temperatures  $kT > \hbar\omega_c^{cv}$   $N_{jds}^{2d}(h\nu, E_{cv}^{2d}(B, T, d, N_L^{cv}, n_z))$  they turn into a persistent combined thickness of states of the quantum well and there will be no feel the impact of a quantizing attractive field. In expansion, as the temperature increments, the sharp crests within the Landau levels of charge carriers, due to the quantization of the energy levels of electrons and gaps within the permitted quantum well, steadily smooth out. This leads to the reality that at the temperature T=40 K,  $kT=3,5 \cdot 10^{-3}$ ,  $kT \approx \hbar\omega_c^{cv}$  discrete Landau levels of quantum well charge carriers gotten to be invisible. At a temperature of 77 K, the discrete Landau levels within the permitted band of the GaAs/AlGaAs quantum well are nearly imperceptible and coincide with the two-dimensional combined thickness of states within the nonappearance of a magnetic field. Consequently, the two-dimensional

combined thickness of states within the conduction band and within the valence band of the quantum well are watched at temperatures  $kT < \hbar\omega_c^{cv}$ . Beginning from temperatures of the arrange of  $0.5kT \sim \hbar\omega_c^{cv}$ , the two-dimensional combined densities of states due to Landau quantization within the permitted band of the quantum well are not watched.

In this case, the measurements give a continuous spectrum of the two-dimensional combined density of states. Changing the cyclotron frequency of the magnetic field  $\omega_c^{cv}$  changes the energy distance between discrete Landau levels of charge carriers in the quantum well (Fig.4). On Fig.4 shows graphs of the two-dimensional combined density of states in direct-gap heterostructures with GaAs/AlGaAs quantum wells (d=14 nm) at various magnetic fields B=9 T and 12 T. As can be seen from these figures, with an increase in the induction of the quantizing magnetic field, we obtain a change in the discrete peaks of the Landau levels of charge carriers.



**Fig.3. Effects of temperature on the dependence of the two-dimensional combined density of states on the absorbing photon energy in direct-gap heterostructures with GaAs/AlGaAs quantum wells ( $d=14$  nm) under the influence of a quantizing magnetic field  $B=9$  T**

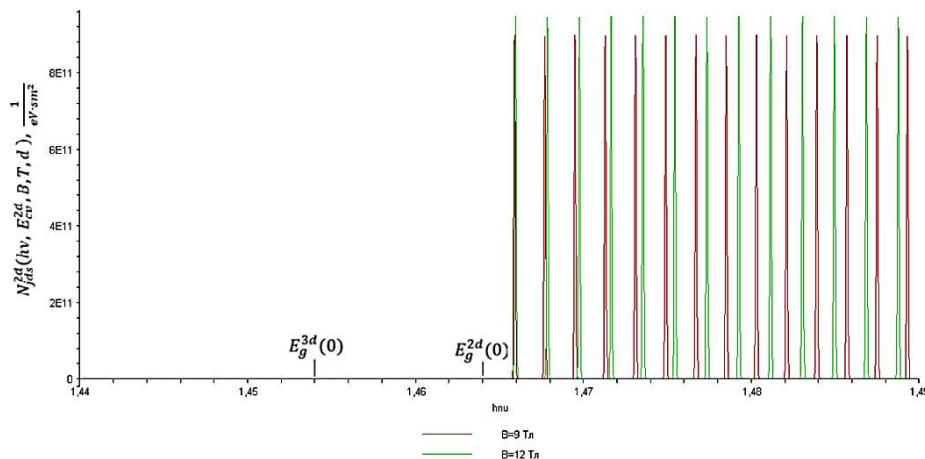

**Fig.4. Influence of a quantizing magnetic field on the dependence of the two-dimensional combined density of states upon absorption of photon energy in direct-gap heterostructures with GaAs/AlGaAs ( $d=14$  nm) quantum wells at a temperature of  $T=4$  K**

As is shown from work [29], the impact of a quantizing magnetic field on two-dimensional electron systems will illustrate exceptionally curiously physical properties emerging from the quantum imprisonment of charge carriers in a quantum well. Since of this quantum imperative, the 2D combined thickness of states of charge carriers in a quantum well shows Van Hove singularities, where within the case of an perfect unbounded zero-dimensional cross section (quantum dab), the combined thickness of states tends to boundlessness for well-defined vitality

values. Restricting a expansive number of 2D combined densities of states to a single vitality esteem leads to striking physical properties such as greatly tall magneto-optical assimilation, expanded thermoelectric control, quantized electronic conductivity, etc. Applications based on these properties seem lead to imperative unused nanotechnological gadgets and optoelectronic devices.

In particular, in work [30], two-dimensional combined densities of states of heterostructures based on an InGaN/GaN quantum well with different

radiation wavelengths (violet, blue, and green) operating at different currents were studied. The results show that the blue shift of the emission with increasing current is associated with a change in the two-dimensional combined density of states. In this work, the dependence of the two-dimensional combined density of states of the InGaN/GaN quantum well on the absorbing photon energy in the absence of a magnetic field ( $B=0$ ) and at temperatures  $T=300$  K (Fig.5) was obtained. Here, the band gap of the InGaN/GaN quantum well is  $E_g(0)=3.2$  eV, and the thickness of the quantum well is  $d=10$  nm.

Now, let's apply the proposed model to the InGaN/GaN material. Fig.6 shows the influence of the quantizing magnetic field on the dependence of the two-dimensional combined density of states of the InGaN/GaN quantum well on the energy-absorbing photon at different temperatures. Here,  $B=10$  T,  $T=300$  K, 77 K and 5 K. Figures 5 and 6 show similar

results with and without a magnetic field at room temperature. At room temperature, the influence of the magnetic field is not felt when the photon energy of the two-dimensional combined density of states is absorbed, since  $kT \gg \hbar\omega_c$ . The combined density of states behaves as if there is no magnetic field.

**Discussion.** It follows from this that the proposed model obeys certain laws, and this indicates the correctness of the model.

Using equation (9), one can observe oscillations of the two-dimensional combined density of states (6) at different low temperatures. Also, a new analytical expression (the proposed new model) allows one to obtain the results of changes in the thickness of the quantum well associated with the combined density of states. This leads to a theoretical analysis of a number of experimental data.

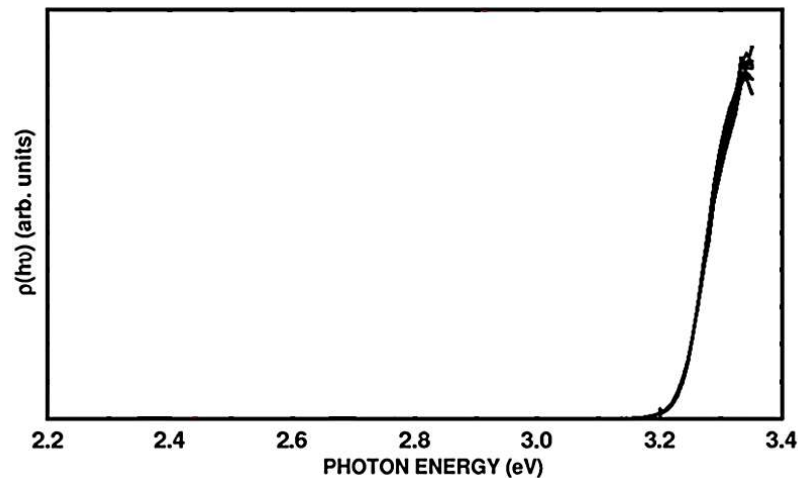

**Fig.5. Dependence of the two-dimensional combined density of states on the energy-absorbing photon in direct-gap heterostructures based on an InGaN/GaN quantum well in the presence of a magnetic field and at room temperature [30]**

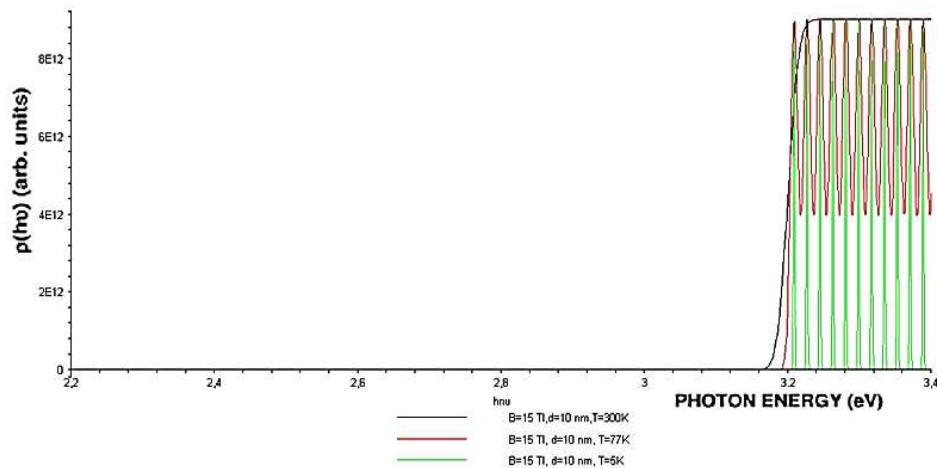

**Fig.6. Influence of temperature and quantizing magnetic field on the two-dimensional combined density of states in direct-gap heterostructures based on the InGaN/GaN quantum well. Calculated using the model**

**Conclusion.** Based on the work carried out, the following conclusions can be drawn: An analytical expression is obtained for the oscillations of the two-dimensional combined density of states in the allowed band of a quantum well under the action of a quantizing magnetic field. A new model has been developed for calculating the effect of a quantizing magnetic field on the temperature dependence of the two-dimensional combined density of states in direct-gap heterostructures with quantum wells. The temperature dependence of the oscillations of the two-dimensional combined density of states of the quantum well is explained by the thermal smearing of the Gaussian distribution function in a strong magnetic field. Based on the proposed new models, the Landau levels of charge carriers in a direct-gap quantum well are determined in a wide temperature range. The experimental results were interpreted using the oscillations of the combined density of states of the quantum well in a quantizing magnetic field. The calculation results were compared with experimental results obtained for heterostructures based on an InGaN/GaN quantum well in a quantizing magnetic field at various temperatures.

### References

1. G.Gulyamov, U.I.Erkaboev, P.J.Baymatov and A.G.Gulyamov. *International scientific journal for alternative energy and ecology*. № 07-09(2017) 112-120.
2. G.Gulyamov, U.I.Erkaboev and P.J.Baymatov, *International scientific journal for alternative energy and ecology* № 19-20 (2016) 130-138
3. L.R.Ram Mohan, Peter A.Wolff, *Physical Review B*. 26, 12 (1982) 6711-6718.
4. M.L.Badgutdinov, A.É.Yunovich, *Semiconductors*, 42, 4 (2008) 429–438.
5. V.E.Kudryashov, A.N.Turkin, A.E.Yunovich, A.N.Kovalev, F.I.Manyakhin. *Semiconductors*, 33, 4 (1999) 429–434.
6. Shyamal Bhar, Soumen Kumar Roy. *Computer Physics Communications*, 184 (2013) 1387–1394.
7. C.I.Cabrera, D.A.Contreras-Solorio, L.Hernández. *Physica E*. 76 (2016) 103–108.
8. J.Hwang, J.D.Phillips. *Physical review B*, 83(2011) 195327-1-195327-7.
9. Johnson Lee, Harold N. Spector, Wu Ching Chou, Ying Sheng Huang. *Physical review B*, 72 (2005) 125329-1-125329-11.

10. Dawei Shen, Jinkui Dong, Jialin Shen, Yan Zhang, Binping Xie, Gang Wu, Xianhui Chen, Lei Fang, Haihu Wen, Donglai Feng. *Journal of Physics and Chemistry of Solids*, 69 (2008) 2975– 2977.
11. T.S.Moss, G.J.Burrell, B.Ellis. *Semiconductor opto-electronics*. (Butterworth & Co.Ltd. 1973) 102-130.
12. N.F.Mott, E.A.Davis. *Electronic processes in non-crystalline materials*. (Clarendon press. Oxford. 1971) 250-282.
13. A.Kulkarni, D.Guney, A.Vora. *Nanomaterials*, 2013(2013), 504341
14. U.I.Erkaboev, G.Gulyamov, R.G. Rakhimov, *Indian Journal of Physics*, 96, 8 (2022) 2359–2368.
15. U.I.Erkaboev, U.M.Negmatov, R.G.Rakhimov, J.I.Mirzaev, N.A.Sayidov. *International Journal of Applied Science and Engineering*, 19, 2 (2022) 2021123.
16. U.I.Erkaboev, G.Gulyamov, J.I.Mirzaev, R.G.Rakhimov, N.A.Sayidov. *Nano*, 16, 9 (2021) 2150102.
17. U.I.Erkaboev, R.G.Rakhimov, N.A.Sayidov. *Modern Physics Letters B*, 35, 17 (2021) 2150293.
18. G.Gulyamov, U.I.Erkaboev, N.A.Sayidov, R.G.Rakhimov. *Journal of Applied Science and Engineering*, 23, 3 (2020) 453–460.
19. U.I.Erkaboev, G.Gulyamov, J.I.Mirzaev, R.G.Rakhimov. *International Journal of Modern Physics B*, 34, 7 (2020) 2050052.
20. G.Gulyamov, U.I.Erkaboev, R.G.Rakhimov, J.I.Mirzaev. *Journal of Nano- and Electronic Physics*, 12, 3(2020) 03012.
21. L.V.Grigoriev. Silicon photonics. Course of lectures (part 1).(St. Petersburg: ITMO University, 2016)
22. G.Gulyamov, U.I.Erkaboev, N.Yu.Sharibaev, *Semiconductors*, 48, 10 (2014) 1323-1328.
23. G.Gulyamov, U.I.Erkaboev, N.Yu.Sharibaev, *Modern physics letters B*, 30, 7 (2016) 1650077.
24. G.Gulyamov, U.I.Erkaboev, P.J.Baymatov, *Advances in condensed matter physics*, 2016 (2016) 5434717.
25. G.Gulyamov, U.I.Erkaboev, A.G.Gulyamov, *Advances in condensed matter physics*, 2017 (2017) 6747853.
26. D.Schoenberg, Magnetic oscillations in metals.(New York, Wiley. 1986) pp.350-400.
27. L.S. Stilbans. Physics of semiconductors. ("Soviet Radio", Moscow. 1967) pp. 416-421.
28. A.V.Mikhailov, A.V.Trifonov, O.S.Sultanov, I.Yu.Yugova, I.V.Ignatiev. *Semiconductors*, 56, 7 (2022) 672-676.
29. U.I.Erkaboev, R.G.Rakhimov, N.A.Sayidov, J.I.Mirzaev. *Indian Journal of Physics*, (2022)
30. Yu-Shou Wang, Nai-Chuan Chen, Chun-Yi Lu, Jenn-Fang Chen. *Physica B*, 406 (2011) 4300–4303.

## C O N T E N T S

---

### PRIMARY PROCESSING OF COTTON, TEXTILE AND LIGHT INDUSTRY

---

**A.Shodmonkulov, R.Jamolov, X.Yuldashev**

Analysis of load changes in the chain drive during the drying process of cotton falling from the longitudinal shelves of the drum..... 3

**A.Xomidjonov**

Influence and characteristics of drying mechanisms in leather production on the derma layer..... 8

**J.Monnopov, J.Kayumov, N.Maksudov**

Analysis of elastic fabrics for compression sportswear in the new assortment 13

**S.Matismailov, K.Matmuratova, Sh.Korabayev, A.Yuldashev**

Investigation of the influence of speed modes of the combined drum on the quality indicators of the tape..... 18

**A.Shodmonkulov, K.Jumaniyazov, R.Jamolov, X.Yuldashev**

Determination of the geometric and kinematic parameters of the developed chain gear for the 2SB-10 dryer..... 23

**R.Jamolov, A.Shodmonkulov, X.Yuldashev**

Determination of dryer drum moisture extraction depending on its operating modes..... 27

**A.Djuraev, K.Yuldashev, O.Teshaboyev**

Theoretical studies on screw conveyor for transportation and cleaning of linter and design of constructive parameters of transmissions..... 29

**S.Khashimov, Kh.Isakhanov, R.Muradov**

Creation of technology and equipment for improved cleaning of cotton from small impurities..... 36

**G.Juraeva, R.Muradov**

The process of technical grades of medium staple cotton at gin factories and its analysis..... 40

**I.Xakimjonov**

Literature analysis on the research and development of the method of designing special clothes for workers of metal casting and metal processing enterprises..... 44

### GROWING, STORAGE, PROCESSING AND AGRICULTURAL PRODUCTS AND FOOD TECHNOLOGIES

---

**A.Khodjiev, A.Choriev, U.Raximov**

Improving the technology of production of functional nutrition juices..... 49

**U.Nishonov**

Research in beverage technology intended to support the functions of the cardiovascular system..... 53

---

<b>Z.Vokkosov, S.Hakimov</b>	
Development of new types of vegetable juices and beverages technology...	59
<b>CHEMICAL TECHNOLOGIES</b>	
<b>M.Latipova</b>	
Analysis of the current status of thermoelectric materials and technology for obtaining and manufacturing half-elements.....	66
<b>G.Ochilov, I.Boymatov, N.Ganiyeva</b>	
Physico-chemical properties of activated adsorbents based on logan bentonite.....	72
<b>U.Nigmatov</b>	
Simulation of heat transfer process in absorber channels.....	77
<b>T.Abduxakimov, D.Sherkuziev</b>	
Procurement of local raw materials complex fertilizers with nitrogen-phosphate-potassium containing moisture.....	84
<b>P.Tojiyev, X.Turaev, G.Nuraliyev, A.Djalilov</b>	
Study of the structure and properties of polyvinyl chloride filled with bazalt mineral.....	89
<b>M.Yusupov</b>	
Investigation of phthalocyanine diamidophosphate- copper by thermal analysis.....	95
<b>L.Oripova, P.Xayitov, A.Xudayberdiyev</b>	
Testing new activated coals AU-T and AU-K from local raw materials when filtration of the waste mdea at gazlin gas processing plant.....	101
<b>N.Kurbanov, D.Rozikova</b>	
Based on energy efficient parameters of fruit drying chamber devices for small enterprises.....	107
<b>Sh.Xakimov, M.Komoliddinov</b>	
Basic methods and technological schemes for obtaining vegetable oils.....	113
<b>A.Boimirzaev, Z.Kamolov</b>	
Size-exclusion chromatography of some polysaccharide derivatives from natural sources.....	117
<b>MECHANICS AND ENGINEERING</b>	
<b>U.Erkaboev, N.Sayidov</b>	
Dependence of the two-dimensional combined density of states on the absorbing photon energy in GaAs/AlGaAs at quantizing magnetic field.....	124
<b>I.Siddikov, A.Denmumaxamadiyev, S.A'zamov</b>	
Investigation of electromagnetic current transformer performance characteristics for measuring and controlling the reactive power dissipation of a short-circuited rotor synchronous motor.....	136
<b>Sh.Kudratov</b>	
Evaluation and development of diagnostics of the crankshaft of diesel locomotives.....	141



<b>Z.Khudoykulov, I.Rakhmatullaev</b>	
A new key stream encryption algorithm and its cryptanalysis.....	146
<b>T.Mominov, D.Yuldoshev</b>	
Coordination of the movement of transport types in areas with high passenger flow.....	157
<b>R.Abdullayev, M.Azambayev, S.Baxritdinov</b>	
Analysis of research results according to international standards.....	163
<b>R.Abdullayev, M.Azambayev</b>	
Cotton fiber rating, innovation current developments, prospects for cooperation of farms and clusters.....	168
<b>F.Dustova, S.Babadzhanov.</b>	
Calculation of the load on the friction clutch of the sewing machine.....	174
<b>Z.Vafayeva, J.Matyakubova, M.Mansurova</b>	
Improvement of the design of the shuttle drum in the sewing machine.....	179
<b>A.Obidov, M.Vokhidov</b>	
Preparation of a new structure created for sorting of ginning seeds.....	185
<b>Sh.Mamajanov</b>	
Carrying out theoretical studies of the cotton regenerator.....	192
<b>ADVANCED PEDAGOGICAL TECHNOLOGIES IN EDUCATION</b>	
<b>A.Khojaev</b>	
Methodological issues of organizing internal audits and control of off-budget funds in higher education institutions.....	199
<b>I.Nosirov</b>	
Theoretical foundations of establishing new technologies on personal management system.....	203
<b>Z.Mamakhanova, D.Ormonova</b>	
Specific characteristics of uzbek national art of embroidery.....	209
<b>A.Raximov, M.Khusainov, M.Turgunpulatov, S.Khusainov, A.Gaybullayev</b>	
Energy-saving modes of the heat treatment of concrete.....	213
<b>ECONOMICAL SCIENCES</b>	
<b>M.Bekmirzayev, J.Xolikov</b>	
Prospects for the development of service industries.....	222
<b>A.Ilyosov</b>	
Organizational and economic mechanisms to support the export of industrial products: a comparative analysis of foreign experience and proposals.....	227
<b>I.Foziljonov</b>	
The importance of multiplier indicators in assessing the effectiveness of the cash flow of the enterprise.....	232
<b>K.Kurpayanidi</b>	
Innovative activity of business entities in the conditions of transformation: a retrospective analysis.....	238

---

<b>Sh.Muxitdinov</b>	
Main characteristics of the risk management mechanism in manufacturing enterprises.....	248
<b>Y.Najmiddinov</b>	
Green economy and green growth. initial efforts of sustainable development in Uzbekistan.....	252
<b>E.Narzullayev</b>	
The methods for measuring the effectiveness of social entrepreneurship activity.....	259
<b>E.Narzullayev</b>	
Analysis of the management and development of environmental social entrepreneurship in Uzbekistan.....	265
<b>F.Bayboboeva</b>	
Legal regulation of entrepreneurial activity.....	270
<b>Z.Boltaeva</b>	
Foundations of neuromarketing strategy in industry.....	276
<b>R.Rashidov</b>	
Issues of regional development of small business.....	281
<b>Sh.Abdumurotov</b>	
Methodology for forecasting the competitiveness of an enterprise based on the Elliott wave principle.....	288
<b>S.Goyipnazarov</b>	
Assessment of impact of artificial intelligence on labor market and human capital.....	299
<b>A.Norov</b>	
Evolution of management science.....	307
<b>K.Narzullayev</b>	
Investment process in the republic of Uzbekistan.....	317
<b>Kh.Irismatov</b>	
Statistical analysis of assessment of the volume of the hidden economy in the republic of Uzbekistan.....	322

---