

ISSN 2181-8622

**Manufacturing technology problems**



# **Scientific and Technical Journal Namangan Institute of Engineering and Technology**

INDEX  COPERNICUS  
INTERNATIONAL

**Volume 8  
Issue 4  
2023**



**SLIB.UZ**  
Scientific library of Uzbekistan

## NamMTI ILMiy-TEKNIKA JURNALI

### Tahrir hay'ati a'zolari:

#### Paxtani dastlabki ishlash, to'qimachilik va yengil sanoat

1. Axmadxodjayev X.T., t.f.d., prof. - NamMTI
2. Muradov R.M., t.f.d., prof. - NamMTI
3. Jumaniyozov Q., t.f.d., prof. - "Paxtasanoat ilmiy markazi" OAJ
4. Eshmatov A.B., t.f.d., prof. - Tojikiston Milliy Texnologiyalar Universiteti
5. Xoliqov Q., t.f.d., prof. - NamMTI
6. Ergashev J.S., t.f.d., dots - NamMTI
7. Obidov A.A., t.f.d., dots. - NamMTI

#### Qishloq xo'jaligi mahsulotlarini yetishtirish, saqlash, qayta ishlash va oziq-ovqat texnologiyalari

1. Toshev A., t.f.d., prof., akad. - Janubiy Ural davlat universiteti, Rossiya
2. Banu Yucel., q.x.f.d., prof. - Ege Universiteti, Turkiya
3. Alimov U., t.f.d. - O'zR FA UNKI
4. Xudayberdiyev A.A., t.f.d., prof. - NamMTI
5. Sherquziyev D.Sh., t.f.d., prof. - NamMTI
6. Merganov A., q.x.f.d., prof. - NamMTI
7. Mamatov Sh., t.f.d., prof. - Webster Universiteti

#### Kimyo va kimyoviy texnologiyalar

1. Namazov Sh.S., t.f.d., prof., akad. - O'zR FA UNKI
2. Botirov E.X., k.f.d., prof. - O'zR FA O'MKI
3. Akbarov H.I., k.f.d., prof. - O'zMU
4. Boymirzayev A., k.f.d., prof. - NamMTI
5. Nurmonov S.E., t.f.d., prof. - O'zMU
6. Salihanova D.S., t.f.d., prof. - O'zR FA UNKI
7. Kattayev N.T., k.f.d., prof. - O'zMU

#### Mexanika va mashinasozlik

1. Zaynobiddinov S., f.m.f.d., prof., akad. - ADU
2. Mardonov B., f.m.f.d., prof. - TTYSI
3. Usmanov P., f.m.f.d., dots. - NamMTI
4. Matkarimov P.J., t.f.d., prof. - NamMTI
5. Sharibayev N., f.m.f.d., prof. - NamMTI
6. Erkaboyev U.I., f.m.f.d., dots. - NamMTI
7. Musoyev S.S., t.f.n., prof. - BuxMTI

#### Ta'limda ilg'or pedagogik texnologiyalar

1. Goncharenko I.I., f.m.f.d., prof. - BMTU, Belorussiya
2. Hüseyin Kamal, t.f.d., prof. - Ege Universiteti, Turkiya
3. Ergashev Sh.T., t.f.n., dots. - NamMQI
4. Musayev J.P., p.f.d., prof. - IRV
5. Xoshimova D., f.f.d., prof. - NamMTI
6. Maxkamov A.M., t.f.d. - NamMTI

#### Iqtisodiyot

1. Maniki Tiagi, i.f.d. - KIET, Xindiston
2. Malcolm Ng Cher Herh., t.f.d. - INTI IUC, Malaysia
3. Soliyev A., i.f.d., prof. - NamMTI
4. Saidboyev Sh., i.f.d., prof. - NamMTI
5. Matkarimov K., i.f.n., prof. - NamMTI
6. Kadirova X.T., i.f.d., dots. - NamMTI
7. Bustonov M.M., i.f.d., dots. - NamMTI

### Muharrirlar guruhi

S. Yusupov, O. Kazakov, B. Xolmirzayev, A. Mirzaev,  
A. Tursunov, O. R. Qodirov (mas'ul muharrir)

14. O'zbekiston Respublikasi Vazirlar Mahkamasining "O'zbekiston Respublikasi Prezidenti huzuridagi Davlat boshqaruvi akademiyasining hududiy filiallari faoliyatini tashkil etish chora-tadbirlari to'g'risida" 2018 yil 28 sentyabrdagi 772-sonli Qarori.

15. <https://dba.uz/wp-content/uploads/2019/09/malaka-oshirish.jpg>

16. "O'zbekiston Respublikasi Prezidenti huzuridagi davlat boshqaruvi akademiyasida boshqaruv kadrlarini tayyorlash, qayta tayyorlash va malakasini oshirish tizimini takomillashtirishga doir qo'shimcha chora-tadbirlar to'g'risida"gi O'zbekiston Respublikasi Prezidentining PQ-4365-sonli Qarori.

## BLOCK DIAGRAM AND MATHEMATICAL MODEL OF AN INVARIANT SYSTEM

**KHOLHODJAEV BOKHODIR**

Tashkent State Technical University

**KURALOV BEKJON**

Tashkent State Technical University

**DAMINOV KAMOL**

Tashkent State Technical University

**Abstract.** Recently, one of the modern directions of the theory of control, the theory of construction of state monitors of linear and nonlinear dynamic systems has significantly developed [2, 4, 10, 15]. The approach based on the expansion of the system dynamics based on the information of the input and output values due to the construction of a special dynamic system observer whose state converges quickly enough to the initial state of the system over time and the function of the state observer on the output, and the input of the initial system output variables and dynamic feedback can be applied spread out. In this case, the state observer at an arbitrary instant of time is considered as an estimate of the state of the system at a given instant of time [4]. Constructing an observer for a dynamic system is one of the ways to obtain an estimate of the state vector of this dynamic system. Solving such a problem can be of independent value as part of the general problem of dynamic systems control. The article considers the independence of the output value and the error signal from the input actions. In stabilization systems, it is necessary to add independence of the output value from the disturbing influence. The system is invariant with respect to the perturbing influence, if after the completion of the transient process determined by the initial conditions, the system error does not depend on this influence [12-16].

**Keywords:** automatic control system, invariance, input signal filtering, normalized polynomials, dispersion control, mathematical model, dynamic.

**Introduction.** Suppose some control object is described in operator form by an equation of the form

$$A(p)y = B_0(p)u + \sum_{k=2}^{\mu} B_k(p)f_k, \quad p = \frac{d}{dt}, \quad (1)$$

where  $y$  – output manipulated variable;  $u$  – control;  $f_k$  – disturbing influences;  $A(p)$ ;  $B_k(p)$  – polynomials with constant coefficients of degrees  $n$  and  $m_k$ , and  $m_k \leq n$ . Note that (1), in the general case, can be like an equation of a one-dimensional object, and the equation of one of the channels of the multidimensional control object, after the introduction of decomposition control [8].

The task of synthesis is to determine the order and values of all parameters of the control device described by the equation

$$R(p)y = Q_0(p)\varphi - Q_1(p)u - L(p)y + \sum_{k=2}^{\mu} Q_k(p)f_k, \quad (2)$$

where  $\varphi = g - y$  – error signal;  $g$  – impact on the main input of the system. In the general case  $g = f_0 + f_1$ ; and  $f_0$  – defining, and  $f_1$  – disturbing influence;  $f_2, \dots, f_{\mu}$  – measurable perturbations, attached to the object,  $\bar{\mu} \leq \mu$ ,  $R(p)$ ,  $L(p)$ ,  $Q_k(p)$  – polynomials with constant coefficients. Moreover, if the degree of the polynomial is  $r$ , then, according to the realizability conditions, the degree of the remaining polynomials in (2) is at most  $r$ .

Additional feedback loops defined by operators  $Q_1(p)$  and  $L(p)$  in the control device (2), are very essential in the synthesis of invariant systems. It is they that make it possible to “untie” the fulfillment of the conditions of stability and invariance. We emphasize that the expediency of finding a solution to the problem of synthesis of invariant systems in the class of multiloop systems was repeatedly noted in the works of G.V. Shchipanova and especially A.G. Ivakhnenko.

Synthesis of system (1), (2), whose mismatch  $\varepsilon = f_0 - y$  invariant in the sense of V.S. Kulebakin to some impact  $f_k$ ,  $k \in [0, \mu]$ , is carried out on the basis of the dynamic model of the latter, which can be specified in the following ways:

- by using  $K_{pf_k}$  – exposure images  $f_k [3, 5]$ , i.e. a polynomial  $F_k(p)$ , which is in fact an eigenoperator of the homogeneous differential equation

$$F_k(p)f_k = 0$$

- note that this polynomial is equal to the denominator of the image  $f_k(p)$  this impact according to Laplace;

- in the form of an impact spectrum, i.e. a set of numbers  $\{\sigma_{k1}, \sigma_{k2}, \dots, \sigma_{kr_k}\}$  – poles of transformation of this influence according to Fourier or Laplace;

- equations in Cauchy form

$$\square w = F_k w_k = 0, \quad f_k = a_k^T w_k$$

Here  $w_k - r_k$  - dimensional vector of variables;  $F_k$  and  $a_k$  corresponding dimensions matrix and vector of coefficients,  $T$  – transposition operation symbol.

We emphasize that all the above forms of describing the impacts are equivalent to each other, since

$$F_k(p)p^{r_k} + \sum_{i=0}^{r_k-1} \eta_{ki} p^i = \prod_{i=1}^{r_k} (p - \sigma_{ki}) \det(pE - F_k). \quad (3)$$

Here  $E$  – identity matrix.

Regarding impacts  $f_k$   $k \in [0, \mu]$ , the model of which in any of the specified forms is not known, it is only assumed that they are limited in absolute value.

The order and parameters of the controller (2), according to [6, 8], are determined by the closed system equation. In this case, it is convenient to write it relative to the error signal  $\varepsilon = f_0 - y$ . From equations (1) and (2) we obtain

$$H(p)\varepsilon = \sum_{k=0}^{\mu} P_k(p)f_k, \quad (4)$$

where

$$H(p) = A(p)[R(p) + Q_1(p)] + B_0(p)\bar{L}(p), \quad (5)$$

$$P_0(p) = A(p)[R(p) + Q_1(p)] + B_0(p)L(p), \quad (6)$$

$$P_1(p) = -B_0(p)Q_0(p), \quad P_k(p) = -B_k(p)[R(p) + Q_1(p)], \quad k = \bar{\mu} + 1, \dots, \mu, \quad (7)$$

$$P_k(p) = -B_0(p)Q_k(p) - B_k(p)[R(p) + Q_1(p)], \quad k = 2, 3, \dots, \bar{\mu}. \quad (8)$$

Here indicated

$$\bar{L}(p) = Q_0(p) + L(p) \quad (9)$$

For greater concreteness, we also present the conditions for the invariance of control systems. According to [1, 2, 6], the error of system (4) with respect to the impact  $f_k$  will be invariant in the sense of G.V. Shchipanova, if

$$P_k(p) = 0, \quad (10)$$

but in the sense of V.S. Kulebakin, if only

$$P_k(p) = \tilde{P}_k(p)F_k(p), \quad \text{GCD} \{F_k(p), H(p)\} = 1 \quad (11)$$

Here  $\tilde{P}_k(p)$  – some polynomial in  $p$ ; GCD – greatest common divisor.

The stability conditions, taking into account the requirements for the quality of the system, we will take in the form

$$H(p) \in \Omega. \quad (12)$$

Here  $\Omega$  – a set of polynomials whose zeros are located in the region that is admissible from the point of view of the quality of the synthesized system;  $\in$  – belonging sign. Moreover, we will assume that

$$\text{GCD} \{F_k(p), B_k(p)\} = 1, \quad (13)$$

i.e. if part of the perturbation poles  $\bar{f}_k$ , applied to the object (1) coincides with the zeros of the polynomial  $P_k(p)$ , then these poles can be ignored in the polynomial  $F_k(p)$ , since the influence of the corresponding components of the perturbation  $\bar{f}_k$  will be completely suppressed by the object and without control.

In accordance with the analytical, polynomial synthesis method [5, 8], the polynomials  $H(p)$  and  $P_k(p)$ ,  $k = 0, 1, \dots, \mu$ , are assigned in accordance with the desired quality of the designed system and the conditions for the physical feasibility of the control device, and expressions (5) - (8) are considered as equations for unknown parameters of the controller (2).

In practice, this means that in order to solve the problem of synthesis of invariant automatic control systems, it is necessary to be able to assign a polynomial  $H(p)$ , so that it belongs to the multitude  $\Omega$ , and polynomials  $P_k(p)$ ,  $k = 0, 1, \dots, \mu$  in accordance with conditions (10) or (11). Then the conditions under which such assignments are possible, and equations (5) - (8) are solvable with respect to the parameters of the

controller (2), will be the solvability conditions for the problem of synthesis of system (1), (2) invariant in the sense of G.V. Shchipanova or V.S. Kulebakin to one or another effect  $f_k, k \in [0, \mu]$ .

In particular, if  $m_0 = n$ , and  $B_0(p) \in \Omega$  then assuming  $Q_1(p) = -R(p), L(p) \in \Omega, \deg L(p) = \deg R(p)$  and  $Q_k(p) = 0, k = 0, 1, \dots, \bar{\mu}$ , we obtain an absolutely invariant automatic control system to all influences  $f_k, k \in [0, \mu]$  except  $f_1(t)$ .

Absolute error invariance  $\varepsilon = f_0 - y$  system (1), (2) with respect to the perturbation  $f_1(t)$ , applied to the system at one point with the driving force  $f_0$ , achieved only when  $Q_0(p) \equiv 0$ , which is equivalent to turning off the input signal of the system. This condition is obviously obviously impossible, and therefore there is no solution to the corresponding synthesis problem.

**Material and methods.** One of the ways to obtain high accuracy in automatic control systems is the use of invariance theory methods.

Let the linear system be represented by the following equation:

$$A(q^{-1})y(t) = B(q^{-1})u(t - k) + D(q^{-1})w(t - d), \tag{14}$$

where:  $y(t)$  – output,  $u(t)$  – input and  $w(t)$  measured perturbation.

the inverse  $q^{-1}$  shift operator, the polynomials  $A, V$ , and  $D$  have zero coefficients in the large fractions.  $na, nb$  and  $nd$  are their degrees [1].

$A(q^{-1})$  a polynomial can be normalized and a stable polynomial,  $B(q^{-1})$  and a polynomial can be unstable. Turbulence is represented using the following equivalent stochastic model

$$w(t) = \frac{G(q^{-1})}{H(q^{-1})}v(t), \tag{15}$$

where:  $N$  and  $G$  are constant and normalized polynomials.  $v(t)$  a white stationary process has zero mean and  $\Delta_v$  variance.

The problem is to synthesize the correct coupling stable rectifier illustrated in Figure 1.

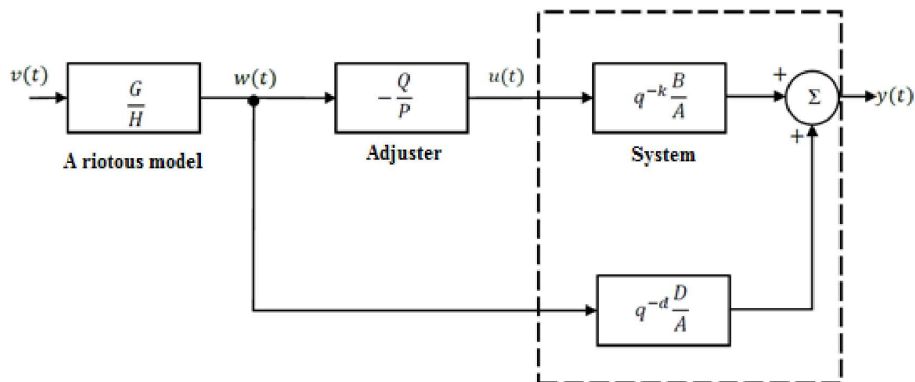

**Fig. 1. The structure of the direct communication control system**

$$u(t) = -\frac{Q(q^{-1})}{P(q^{-1})}w(t), \quad (16)$$

where  $P$  is a normative polynomial, the conditions for minimizing the quality criterion in the following form [2].

$$J = Ey(t)^2 + \rho E(\tilde{\Delta}(q^{-1})u(t))^2. \quad (17)$$

For minimal-phase systems with sufficient delay time ( $B$  steady), the following is the case

$$u(t) = -q^{-d+k} \frac{D(q^{-1})}{B(q^{-1})}w(t)$$

described by the relationship ( $d \geq k$ ) provides ideal control with the help of correct contact ( $y(t) = 0$ ) [3-5, 7-9].

Next, we will use the following polynomials of various forms

$$D = D(z) = d_0 + d_1z + \dots + d_{nd}z^{nd},$$

here we replace  $z$  with  $q^{-1}$ .

Interrelated polynomials :

$$D_* \stackrel{\Delta}{=} D(z^{-1}) = d_0 + d_1z^{-1} + \dots + d_{nd}z^{-nd}.$$

Inverse polynomials :

$$\bar{D} \stackrel{\Delta}{=} z^{nd} D_* = d_0z^{nd} + d_1z^{nd-1} + \dots + d_{nd}.$$

$\bar{D} D$  reflected around the unit radius.

If  $D$  is stable,  $\bar{D}$  it must be unstable.  $D_c$  and  $D_u$   $D$  denote the stable and unstable part of the polynomial.  $D'$  denotes the polynomial associated with the input signal estimation problem [7-9, 10-15].

We use spectral factorization

$$r\beta\beta_* = BB_* + \rho A\tilde{\Delta}\tilde{\Delta}_*A_*, \quad (18)$$

where  $\tilde{r}$  - is a positive scalar coefficient,  $\beta$  and  $\beta_*$  is a stable normalized polynomial of the following degree in  $z$

$$n\beta = \begin{cases} nb & n\mu \rho = 0 \\ \max\{nb, na + \deg \tilde{\Delta}\} & n\mu \rho > 0. \end{cases}$$

$\rho > 0$  in order to have a stable spectral factor when in a minimum dispersion control  $\rho = 0$ ,  $V$  cannot be zero around a unit radius. If these conditions are fulfilled, then (16) is a well-connected adjuster (14), (15) for a stable system, when restricting the adjuster to stability (17) ensures obtaining the global minimum value of the criterion [5], if:

1)  $R$  is determined from the following expression

$$P = \beta G, \quad (19)$$

here is  $\beta$  the constant spectral factor in (18).

2)  $Q_*(z^{-1})$  and  $L(z)$

$$\begin{aligned} nQ &= \max\{na + nh - 1, nd + ng + d - k\}, \\ nL &= \max\{n\beta, nb - d + k\} - 1. \end{aligned} \quad (20)$$

the following rank

$$z^{-d+k} BD_* G_* = r\beta Q_* + A_* H_* zL$$

is the solution of the equation.

Let us consider the stochastic equation with discrete variable expressed as follows

$$y(t) = \frac{B'(q^{-1})}{A'(q^{-1})} u(t-k) + \frac{M'(q^{-1})}{N'(q^{-1})} v(t), \quad (21)$$

the unknown  $u(t)$  input sequence is expressed as

$$u(t) = \frac{C'(q^{-1})}{D'(q^{-1})} e(t), \quad E v(t)^2 / E e(t)^2 = \rho. \quad (22)$$

All parameters of the system are assumed to be stable.

$A', D'$  and  $N'$  polynomials can be stable and normed,  $C'$  and  $M'$  polynomials can be stable,  $M', C'$  and  $B'$  polynomials can be unstable [5, 14].

$v(t)$  and  $e(t)$  sequences of white noise are assumed to be stationary with zero mean and uncorrelated. The task is to determine a stationary linear estimator for the input

$$\hat{u}(t | t-m) = \frac{Q(q^{-1})}{P(q^{-1})} y(t-m), \quad (23)$$

it minimizes the mean squared error of estimation [1, 2, 5]

$$E z(t)^2 \stackrel{\Delta}{=} E (u(t) - \hat{u}(t | t-m))^2. \quad (24)$$

Depending on the size of  $(m > 0)$   $m$ , one can obtain input prediction,  $(m = 0)$  filtering, or  $(m < 0)$  fixed-delay smoothing problem.

It is known that the minimum achieved error of estimation decreases with decreasing  $m$ .

**Results and discussion.** The problem statement consists of filtering  $A' = B' = 1, k = 0$  the output (evaluation of Figure 2  $f(t)$ ) as a separate case.

minimum-phase ( steady-state) systems with  $B'$  undisturbed outputs  $(\rho = 0) u - m - k$ , input recovery can be obtained using an inverse system.

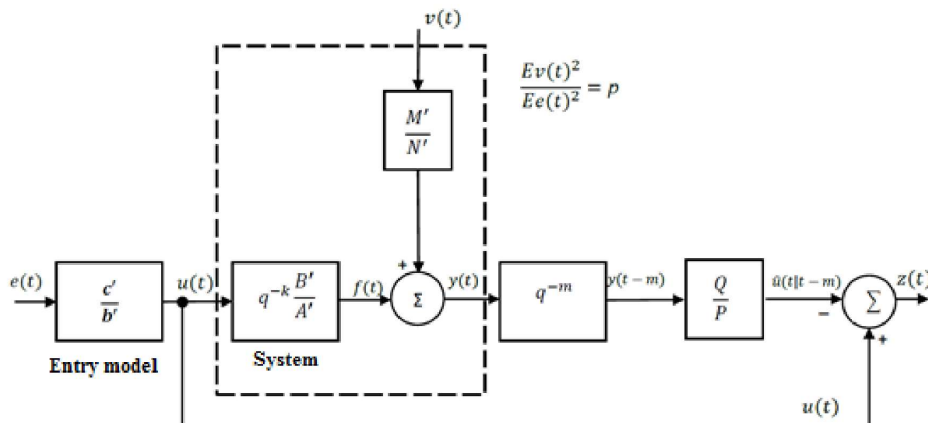

**Fig. 2. The structure of the problem of evaluation of riots**



$$\hat{u}(t-k|t) = \frac{A'(q^{-1})}{B'(q^{-1})} y(t) = u(t-k).$$

Spectral factorization is required to obtain a general solution

$$r\beta' \beta'_* = C'B'N'C'_*B'_*N'_* + \rho M'A'D'M'_*A'_*D'_*, \quad (25)$$

where  $r$  is a positive scalar factor,  $\beta'(z)$  and is a constant and normative polynomial of the following degree in  $z$ :

$$n\beta' = \begin{cases} nc' + nb' + nn' & \text{azap } \rho = 0 \\ \max\{nc' + nb' + nn', nm' + na' + nd'\} & \text{azap } \rho > 0. \end{cases}$$

$\rho > 0$  in order to be stable when  $\beta'$  (25) it is necessary and sufficient to accept two segments that do not have zero common multipliers in the unit circle on the right side of [1, 5].

( $\rho=0, N=10$ ),  $C'$  and  $B'$  there should be no zeros around the unit radius in the absence of noise. If there is stability  $\beta'$ , (24) the estimation filter of the input signal (21), (22) ensures obtaining the global minimum value of the estimation error at the stability limits of the filter (24) for systems [2, 3, 4, 7, 12], if

$$\frac{Q}{P} = \frac{Q_1 N' A'}{\beta'}, \quad (26)$$

if here  $\beta'$ , the stable spectral factor derived from (25) is the following  $L(z)$

$$nQ_1 = \max\{nc' - m - k, nd' - 1\},$$

$$nL = \max\{nc' + nb' + nn' + m + k, n\beta'\} - 1. \quad (27)$$

rank  $z^{m+k} C'B'N'C'_* = r\beta'Q_1 + D'_*zL$  system.

In order to more clearly demonstrate the relationship between management and evaluation issues, we replace the evaluation issue presented in Figure 3 and illustrated in Figure 2.

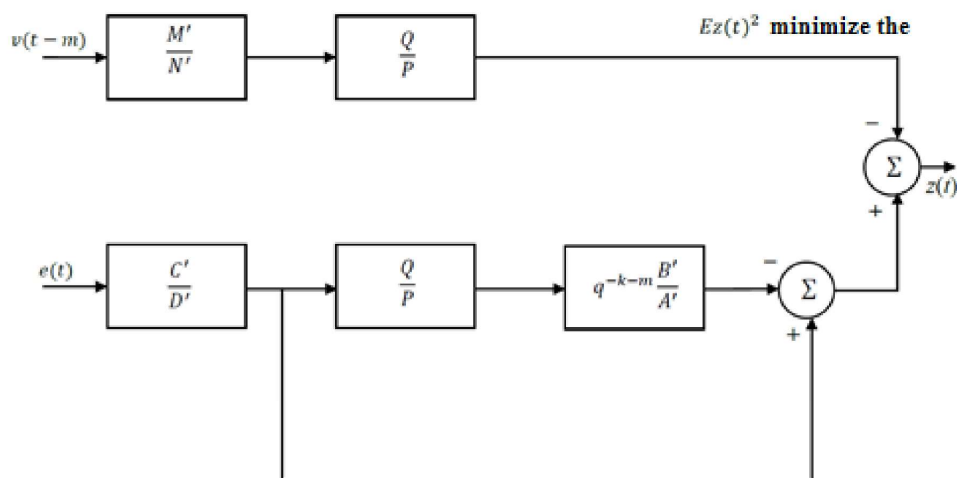

**Fig. 3. Communication structure between management and evaluation issues**

In Figure 3, the lower channel becomes a structure in the case of a well-coupled matching control, where  $Q/P$  - corresponds to the rectifier that needs to be synthesized.

It should be noted that when  $u_1(t)$  the signal in the upper channel is not correlated with  $u(t)$  and  $y(t)$ , its dispersion  $\rho Eu(t)^2$  is determined by the expression, as well as

$$Ev(t)^2 / Ee(t)^2 = \rho.$$

Thus, criterion (22) can be written in the following form

$$Ez(t)^2 = E(y(t) + u_1(t))^2 = Ey(t)^2 + Eu_1(t)^2 = Ey(t)^2 + \rho Eu(t)^2.$$

**Conclusion.** Comparing the corresponding blocks in Figure 1 with the blocks in Figure 3 allows us to draw the following conclusion. The input evaluation problem defined by the expressions (20)-(22) can be considered as a well-connected equivalent control problem. If  $M'$  is stable,  $Q/P$  the optimal filter can be synthesized using relation (18)-(19).

The mentioned methods allow the use of different algorithms for evaluating input effects in the synthesis of invariant control systems of dynamic systems.

#### References:

1. Egupov N.D., Pupkov K.A. Methods of classical and modern theory of automatic control. Textbook in 5 volumes. - M.: Publishing house of Moscow State Technical University named after N.E. Bauman, 2004.
2. Miroshnik I.V., Nikiforov V.O., Fradkov A.L.. Nonlinear and adaptive control of complex dynamic systems. - St. Petersburg: Science, 2000.
3. Akhobadze A.G., Krasnova S.A. Solution of the tracking problem under uncertainty based on the joint block-canonical form of controllability and observability // Large systems management. – 2009. Issue. 24. -S. 34-80.
4. Akhobadze A.G., Krasnova S.A. Tracking problem in linear multidimensional systems in the presence of external disturbances // Automation and telemechanics. - 2009. No. 6. -S. 21-47.
5. Emelyanov S.V., Korovin S.K. New types of feedback. - M.: Nauka, 1997. -352 p.
6. Fradkov A.L. Adaptive control in complex systems. – M.: Nauka, 1990. – 296 p.
7. Krasnova S.A., Kuznetsov S.I. Sliding Mode Estimation of Uncontrolled Disturbances in Nonlinear Systems // Automation and Telemechanics. 2005. No. 10. -S. 54-69.
8. Agvami S.A., Kolomeitseva M.B. Synthesis of an adaptive neuroregulator for controlling a nonlinear multi-connected object// Bulletin of MPEI. 2011. No. 6. S. 209-215.
9. Krasnova S.A., Utkin A.V. Analysis and synthesis of minimum-phase nonlinear systems under the action of external uncoordinated perturbations // Problems of Control, 2014, No. 6, –S. 22-30.
10. Kholkhodzhaev B.A. Algorithms for estimating autoregression coefficients under conditions of incomplete information / Collection of materials of the international scientific technical conference "Modern materials, equipment and technologies in mechanical engineering". April 19-20, 2014 Andijon-2014. Page 138-139.
11. Kholkhodzhaev B.A. Algorithm for estimating unknown input signals in dynamic control systems / Zamonaviy ishlab chiqarishning muhandislik va technologist muammolarini innovation echimlari. Khalqaro ilmiy anzhuman materiallari. II vol. November 14-16, 2019 Bukhoro s. 228-230.

12. Burov V.D. "Thermal power plants" Textbook. - 3rd ed., stereotype. - Moscow: MEI Publishing House, 2009. - 466 p.
13. Shidlovsky S.V. Automatic control. Perestraivaemye structure. – Tomsk: Tomsk State University, 2006. – 288 pp.
14. Kholkhodzhaev B.A. Algorithms for the synthesis of multifunctional state monitors for linear system.// "Technical science and innovation", №2/2020, Page: 92-96. Tashkent 2020.
15. Kholkhodzhaev B.A. Algorithms to restore the input effects of dynamic systems in conditions of uncertainty.// "Technical science and innovation", №4/2020, Page:150-154. Tashkent 2020.
16. Kholhodjaev B.A. Construction of a structural-mathematical model reservoirs / International Scientific and Practical Conference "Ecological problems of food security" Voronezh (EPFS 2022)

## IMPROVING STUDENTS SPEAKING SKILLS IN PRACTICAL LESSONS

**MAMADALIYEVA BURAYMA**

Teacher of Namangan Institute of Engineering and Technology  
E-mail.: [reynamamadaliyeva@gmail.com](mailto:reynamamadaliyeva@gmail.com), phone.: (+99897) 680 88-80

**Abstract:** This article focuses on improving students' speaking skills in practical English classes. According to the results of interviews conducted in order to obtain preliminary data on students' speaking skills, it was found that students face problems in speaking due to their insufficient knowledge of the language, which in turn makes students feel insecure about speaking. . Students were not familiar with different speaking activities that facilitate speaking. They read text to convey ideas and lack strategies when speaking. To help students, task-based learning is adapted through action research in courses. 15 students in these courses participate in this study. Data is collected from pre-test to post-test to interview. Findings show that using task-based learning helps students improve their speaking skills on four dimensions: accuracy, vocabulary, fluency, and comprehension. Students succeed in completing tasks by engaging in a variety of activities at three stages of learning: pre-task, task-cycle, and form-focus. They manage to improve their speaking skills and gain self-confidence. Students can assess their knowledge in pair and group work.

**Keywords:** pre-test, post-test, interview, speaking skills, task-cycle, form-focus, accuracy, vocabulary, fluency, comprehension.

**Introduction.** One of the most necessary skills for living in the twenty-first century is gaining the ability to know and use another language. In many areas of life, from business transactions to broadcasting television weather warnings, the demand for proficiency in a foreign language is growing. One of the most important skills to have in a foreign language is the ability to speak the language with native or non-native speakers of that language. A great number of foreign language learners most likely consider one of their primary language goals to be the ability to speak the

language at a high level of proficiency. Thus, oral proficiency has become an important focus in the foreign language classroom. Learners in a foreign language classroom are primarily exposed to four different communication skills: reading, writing, listening, and speaking. Of these four skills, speaking is generally regarded as the most difficult in which to attain proficiency due to its complex nature. Though each of the four language skills can be taught in conjunction with another of the skills, it is important to look at speaking here in isolation. Speaking is considered the most important skill compared to the

## C O N T E N T S

<b>PRIMARY PROCESSING OF COTTON, TEXTILE AND LIGHT INDUSTRY</b>	
<b>N.Usmanova, M.Abdukarimova, Sh.Mahsudov</b>	
Information modules for automation of the process of forming the structure of industrial collection of women's clothing.....	<b>3</b>
<b>O.Turdiyeva, A.Khojiyev</b>	
Research analysis of transformation new assortment development.....	<b>10</b>
<b>M.Rasulova, Sh.Mamasoliyeva, G.Norboyeva</b>	
Evaluation of heat conductivity of special clothing.....	<b>15</b>
<b>D.Rayimberdiyeva, N.Nabidjanova, N.Ismailov</b>	
Mathematical model of the influence of a gymnast's strength on clothing fabric.....	<b>22</b>
<b>G.Gulyaeva</b>	
Modeling of strength reliability and transformation of a knitted loop at the limit state of the structure.....	<b>26</b>
<b>H.Diyorov</b>	
Experimental determination of the cleaning efficiency of the fiber in the pipe..	<b>31</b>
<b>S.Khashimov, R.Muradov</b>	
Problems in cleaning cotton-seed and their solution.....	<b>35</b>
<b>GROWING, STORAGE, PROCESSING AND AGRICULTURAL PRODUCTS AND FOOD TECHNOLOGIES</b>	
<b>N.Kurbanov, S.Bozorov</b>	
Development prospects of the oil production industry in the republic of Uzbekistan and foreign countries.....	<b>41</b>
<b>Sh.Rasulov, Kh.Djuraev, A.Usmanov, M.Khalikov</b>	
Kinetics of drying process of tomato fruit.....	<b>45</b>
<b>M.Sobirova, J.Farmonov</b>	
Oil extraction studies from flax seeds.....	<b>52</b>
<b>M.Meliboyev, G.Makhmudova, N.Muydinova</b>	
Importance of potato powder extraction technology in production and industry.....	<b>56</b>
<b>CHEMICAL TECHNOLOGIES</b>	
<b>E.Panoev, Kh.Dustov, J.Jamolov</b>	
Research of corrosion and foaming processes in gas absorption purification and technology of their protection in inhibitors.....	<b>61</b>
<b>U.Odamov, M.Komilov</b>	
Assessment of the degradation process of solar photovoltaic plants in the climatic conditions of Uzbekistan.....	<b>69</b>
<b>R.Dusanov, Kh.Turaev, P.Tojiev, D.Nabiev, KH.Eshankulov</b>	
Physical-mechanical properties of composite materials based on vermiculite, bazalt, wollostanite, and polyethylene P-Y 342 and polyamide PA-6.....	<b>77</b>
<b>Z.Voqqosov, M.Ikromova</b>	
Bentonite and phosphorite production of organomineral fertilizers based on raw materials and nitrogen-fixing microorganisms ((CD:B:NFM=100:5:(0-4)), (CD:B:PF:NFM=100:5:5:(0-4))).....	<b>81</b>
<b>D.Abdirashidov, Kh.Turaev, P.Tajiyev</b>	

Studying the structure and properties of polypropylene filled with nitrogen, phosphorus, metal-containing oligomers.....	<b>90</b>
<b>M.Khoshimkhodjaev, M.Khuramova</b>	
Optimization of the method for instrumental neutron activation analysis (inaa) of natural objects.....	<b>100</b>
<b>F.Rakhmatkariyeva, M.Koxxarov, Kh.Bakhronov</b>	
Isotherm of ammonia adsorption in zeolite CaA (M-22).....	<b>105</b>
<b>R.Kurbaniyazov, A.Reymov, B.Pirnazarov, Sh.Namazov, O.Badalova, B.Beglov</b>	
Rheological properties of ammophosphate pulps obtained using phosphorite powder of the khodjakul deposit.....	<b>111</b>
<b>F.Eshkurbonov, A.Rakhimov, J.Rakhmonkulov, E.Safarova, A.Ashurova, N.Izzatillayev, M.Bobokulova</b>	
Investigation of the chemical-mineralogical composition of bentonite of the khaudag deposit and synthesis of wine fining agents based on its.....	<b>117</b>
<b>J.Shukurov</b>	
Modeling the production of dimethyl ether from natural gas.....	<b>126</b>
<b>D.Makhkamova, Z.Turaev, M.Dedaboyeva</b>	
Study of interaction of components in $ZnSO_4 - NH_4H_2PO_4 - H_2O$ system....	<b>137</b>
<b>D.Akhunov</b>	
Study of the problems of atmospheric waste water collection and green field irrigation.....	<b>142</b>
<b>D.Jumaeva, R.Akhrorova, S.Barnoeva, O.Kodirov, U.Raximov</b>	
Study of adsorption isotherms of polar and non-polar molecules on silica adsorbents.....	<b>146</b>
<b>MECHANICS AND ENGINEERING</b>	
<b>E.Abdullaev, V.Zakirov</b>	
Using parallel service techniques to control system load.....	<b>154</b>
<b>E.Aliyev, A.Mamaxonov</b>	
Development of efficient chain transmission construction based on analysis of constructive characteristics of chain drives of technological machines.....	<b>161</b>
<b>S.Utaev, A.Turaev</b>	
Results of a study of the influence of oil contamination on wear of the working surface of diesel cylinder lines.....	<b>171</b>
<b>L.Tilloev, Kh.Dustov</b>	
Separation of the polymer mass from the waste of the alkaline cleaning process of pyrogas by the extraction method.....	<b>177</b>
<b>A.Mirzaalimov</b>	
Effect of temperature on photoelectric parameters of three-way illuminated solar cells.....	<b>183</b>
<b>Sh.Mamajanov, A.Qakhharov, Sh.Isaboyev</b>	
On training of competitive personnel - on the basis of creating a new generation of teaching literature in the educational process (in the example of mechanical science).....	<b>193</b>
<b>K.Ismanova</b>	
Mathematical model and analytical solutions of the process of physics-chemical hydrodynamics.....	<b>197</b>
<b>N.Sharibayev, B.Nasirdinov, G.Rasulova</b>	

Microcontroller-based mechatronic system with heating and humidity sensor for silkworm eggs incubation.....	<b>205</b>
<b>M.Rasulmuhamedov, K.Tashmetov, T.Tashmetov</b>	
Methods of determining transport flows.....	<b>210</b>
<b>J.Izzatillaev, U.Khudoyberdiev, X.Mamadiev</b>	
Prospects for the application of vertical axis wind turbines in the Jizzakh region.....	<b>218</b>
<b>Y.Asatillaev, N.Israilov</b>	
Problems and possibilities of laser synthesis of metal powders in additive technologies.....	<b>230</b>
<b>U.Meliboev, D.Atambaev</b>	
Determination of acceptable values of the main factors affecting the production of twisted thread.....	<b>237</b>
<b>N.Adilov</b>	
Assessment of the technical condition of the weight checking wagon type 640-VPV-271.....	<b>242</b>
<b>ADVANCED PEDAGOGICAL TECHNOLOGIES IN EDUCATION</b>	
<b>M.Ikromova</b>	
Programming as one of the main approaches in the development of children's komputational thinking.....	<b>247</b>
<b>A.Yuldashev</b>	
Developing activities, the academy of public administration under president of the republic of Uzbekistan.....	<b>253</b>
<b>B.Kholhodjaev, B.Kuralov, K.Daminov</b>	
Block diagram and mathematical model of an invariant system.....	<b>259</b>
<b>B.Mamadaliyeva</b>	
Improving students speaking skills in practical lessons.....	<b>267</b>
<b>G.Rasulova</b>	
A lexical-semantic study of terms related to agricultural technology in Uzbek and English languages.....	<b>273</b>
<b>ECONOMICAL SCIENCES</b>	
<b>M.Bustonov</b>	
Digital economy and employment.....	<b>279</b>
<b>M.Bustonov</b>	
Econometric analysis of the activities of multi-sectoral farms.....	<b>285</b>
<b>M.Rahimova</b>	
Prospects for the development of small and medium business in Namangan region.....	<b>292</b>
<b>A.Abdullayev, H.Djamalov</b>	
Organizational structure of the internal control service for the fulfillment of tax obligations of enterprises.....	<b>297</b>
<b>H.Djamalov, A.Abdullayev</b>	
Issues of organizing internal control of fulfillment of tax obligations of enterprises.....	<b>307</b>
<b>Sh.Maripova</b>	
Specific features of management in small business enterprises.....	<b>316</b>
<b>N.Abdieva, R.Abdullayeva, U.Rajabov</b>	
The constituent elements and the need for state regulation of small business and private entrepreneurship.....	<b>324</b>